

### IMPORTANT - DECLARATIONS & WARNINGS

All Barn Light Australia lighting products are designed to be assembled, installed, and finished by a fully-licensed Electrician.

For outdoor ratings to be valid, junctions between the mounting surface and the luminaire must be sealed using supplied gaskets, with an outdoor-rated, UV Resistant silicon used on the mounting surfaces.

Broke something? Might have lost parts? - Call Barn Light. We've got spares. If you believe any facet, part, or component is damaged - Call Barn Light. We're here to make your job easier, both now and in the future.

For outdoor locations a dry ceiling is required between the mounting surface and the luminaire. Parts subject to weather should be sealed with silicon/caulking. The Nipple must be sealed with silicon/plumbers tape prior to installation.

### WIRING DIAGRAM - 220V / E27 MODELS

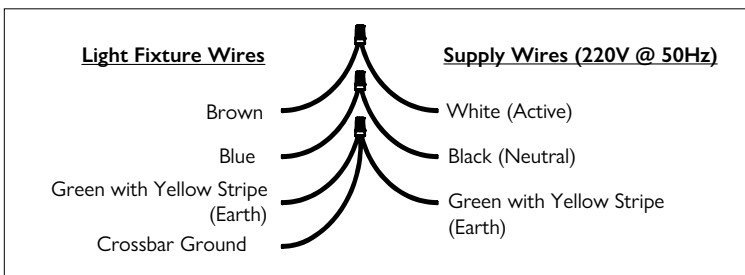

### INSTRUCTIONS - MOUNTING & WARNINGS

1. This installation requires a recessed weatherproof termination point within the structure. Disconnect power from the electrical panel before installation.
2. If using, place the **Adaptor Bracket (A)** (Recommended) on the ceiling side.
3. Place **Stem Mount Gasket (J)** on the ceiling side of the **Stem Mount Canopy (S)**. Ensure punched crosses in Gasket align with threaded holes of **Adaptor Bracket (A)** (See Inset). Affix the **Stem Mount Gasket (J)** with sticky side up.
4. Feed Active, Neutral and Earth wires from **Shade / Fixture (I)** through **Nipple (N)**. Finish towards the ceiling side of the **Stem Mount Canopy (S)**
5. Use **Terminal Block (G)** to connect power supply to the respective wire(s).
6. Affix the **Stem Mount Canopy (S)** to the **Adaptor Bracket (A)** using **Pan Phillips Screws (F)** OR using your desired **Mounting Screws (C)** to **Ceiling (B)**
7. Affix Plumbers Thread tape to **Nipple (N)** before rotating **Shade/Fixture (I)** anti-clockwise until flush with the **Stem Mount Canopy (S)**.
8. Tighten **Grub Screw (H<sup>5</sup>)** into **Stem Mount Canopy (S)** to finish.

### MOUNTING COMPONENTS

- A) Adaptor Bracket (Optional)
- B) Mounting Surface (ie. Your Wall)
- C) Mounting Screws (Not included)
- F) Pan Phillips Screws (2x 8-32x3/4")
- G) Terminal Block
- H) Grub Screws (3/8" x 1/2")
- I) Shade / Fixture
- J) Stem Mount Gasket
- N<sup>3</sup>) Nipple (Usually Affixed to Stem Mount Canopy)
- S) Stem Mount Canopy \*2 (Same as Chain & Flush Mount Canopy)

### NOTES

- \*1 - **Adaptor Bracket (A)** requires mounting of supplied screws **Pan Phillips Screws (F)** to **Stem Mount Canopy (S)**
- \*2 - **Stem Mount Canopy** & **Chain Mount Canopy** appear identical except for **Nipple (N)** supplied.
- \*3 - **Nipple (N)** is typically affixed to **Stem Mount Canopy (S)**.
- \*4 - For tight installations - Installation of the **Stem Mount Canopy (S)** is made prior to screwing **Shade/Fixture (I)** onto the **Nipple (N)**.
- \*5 - **Grub Screws (H)** uses a 3mm Allen Key

**CAUTION: READ ALL INSTRUCTIONS PRIOR TO ASSEMBLY.  
INSTALLATIONS BY QUALIFIED ELECTRICIANS ONLY**

### ALTERNATE FIXTURE STYLES

These instructions are designed ONLY for 220V E27/Edison Screw Wall Light variants. These instructions may cover many different product types that use the common mounting shown below.

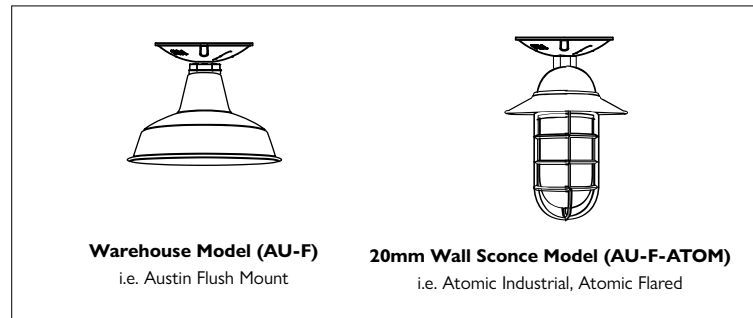

### MOUNTING DIAGRAM

