

IMPORTANT - DECLARATIONS & WARNINGS

All Barn Light Australia lighting products are designed to be assembled, installed, and finished by a fully-licensed Electrician.

For outdoor ratings to be valid, junctions between the mounting surface and the luminaire must be sealed using supplied gaskets, with an outdoor-rated, UV Resistant silicon used on the mounting surfaces.

Broke something? Might have lost parts? - Call Barn Light. We've got spares. If you believe any facet, part, or component is damaged - Call Barn Light. We're here to make your job easier, both now and in the future.

WIRING DIAGRAM - 220V / E27 MODELS

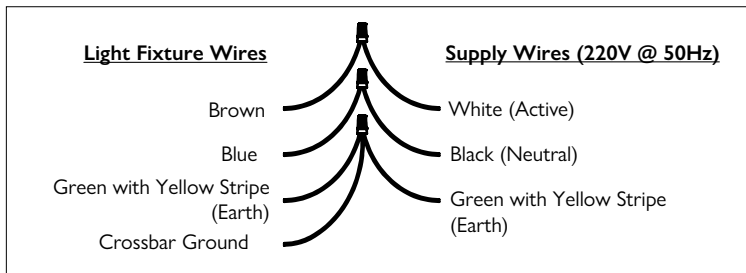

CAUTION: READ ALL INSTRUCTIONS PRIOR TO ASSEMBLY. INSTALLATIONS BY QUALIFIED ELECTRICIANS ONLY

ALTERNATE FIXTURE STYLES

These instructions are designed ONLY for 220V E27/Edison Screw Wall Light variants. These instructions may cover many different product types that use the common mounting shown below.



INSTRUCTIONS - MOUNTING & WARNINGS

1. This installation permits termination outside of the structure. Disconnect power from the electrical panel before installation.
2. Thread **Nipple (D)** into **Crossbar (A)** a few turns until **Nipple (D)** is firmly affixed in place.
3. Seal the **Mounting Surface (B)** with silicon/caulking as required. Affix the **Wall Backing Plate Gasket (J)** center around the **Crossbar (A)** against the wall.
4. Mount **Crossbar (A)** to **Mounting Surface (B)** using **Mounting Screws (C*1)**.
5. Temporarily place lighting fixture against the wall with **Nipple (A)** through centre hole until 6-7mm protrudes out of **Backing Plate (E)**.
6. Remove fixture. Lock **Nipple (D)** into place with Full-size M10 Nut (**F**) tight against the **Crossbar (A)**.
7. Place a single Half-size Nut (**F**) & Tooth Washer directly behind the **Backing Plate (E)** to assist friction when affixing **Lock-Up Cap (I*3)**
8. Using the supplied **Terminal Block (G)** connect the lighting fixture to supply wires. Connect Earth / Ground wire.
9. Affix lighting fixture against the mounting surface. Affix **Lock-Up Cap (I)** tightly against the lighting fixture to finish.
10. Inspect mounting surface to ensure a tight seal is evident. Failure to complete this step will render warranties null and void.

WALL LIGHT COMPONENTS

- A) Crossbar
- B) Mounting Surface (i.e. Your Wall)
- C¹) Mounting Screws (Not included)
- D) Nipple (m10x1.0 Threaded)
- E) Backing Plate (WBP2/WBP3)
- F²) Nuts (m10x1.0 - Half x3, Full x1)
- G) Terminal Block
- H) Tooth Washer
- I³) Lock-Up Cap
- J) Wall Backing Plate Gasket

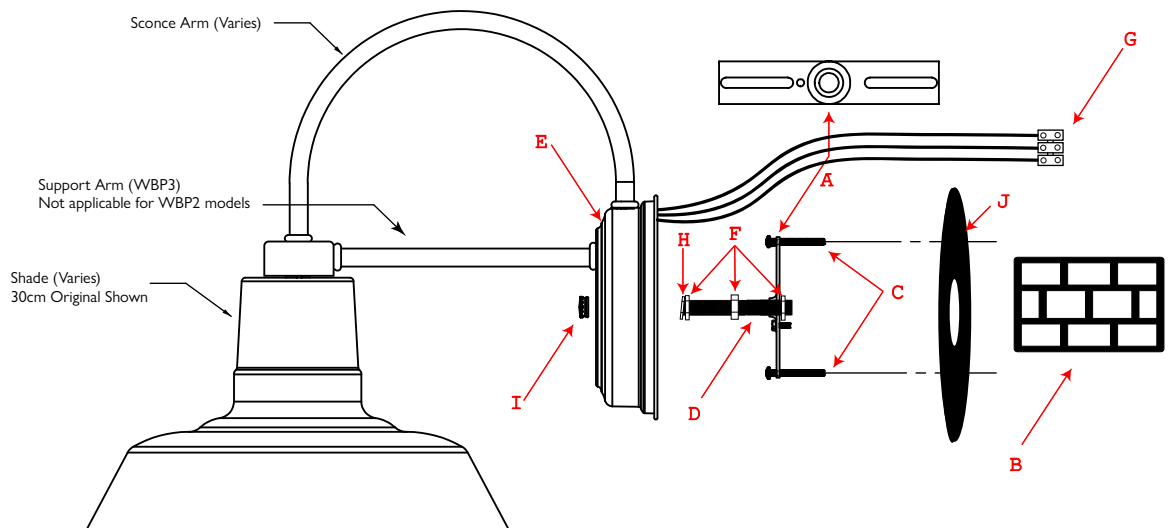

NOTES

- *1 - Mounting Screws (C) are not supplied.
- *2 - Lock-Up Cap (I) - A half-nut (F) may be used to affix Backing Plate (E) against the wall. The Lock-up Cap (I) must always be installed. Silicon the Lock-up Cap (I) if desired.
- *3 - Use of Threadlocker (ie. "Loctite") is encouraged however not required.